

DIMENSIONS IN [mm]

MOTOR 100-B3

L* = DEPENDING UPON MOTOR

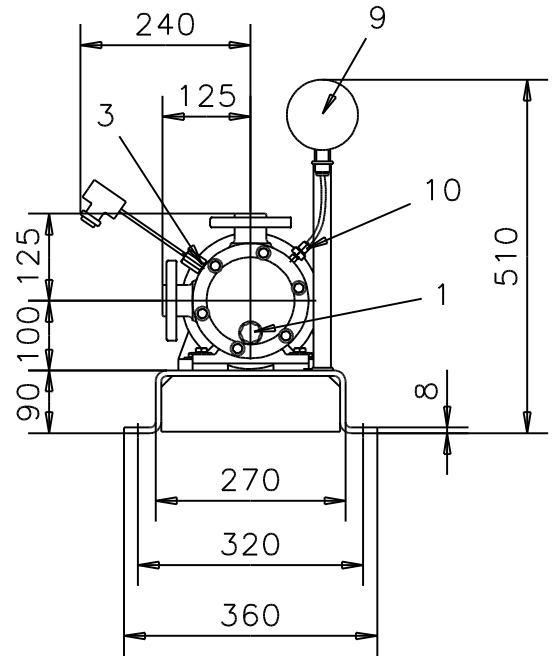
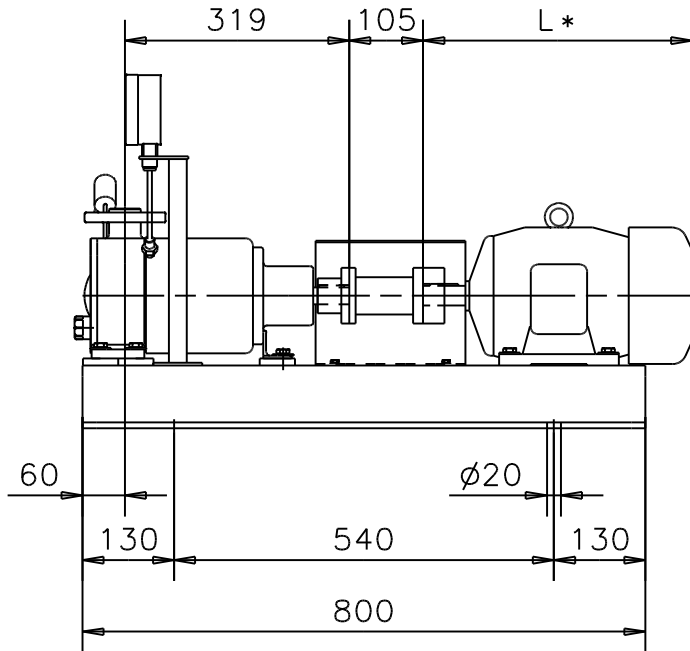

WEIGHT	[kg]
PUMP	20
BASEPLATE ISO NO. 2	30

FLANGE DIMENSIONS EN 1092-1			
DN	k	n $\times\phi$ d	D
25	85	4 \times 14	16

	NO.	SIZE	CONNECTION
X	1	G1/2	DRAIN
X	3	M8 \times 1	TEMPERATURE PT100
X	9	G1/2	GAUGE
X	10	G1/4	SHROUD LEAKAGE MONITORING

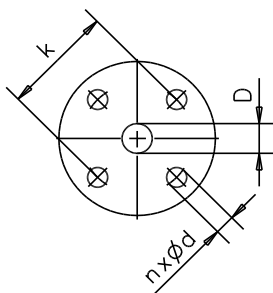

VALID ONLY WITH SIGNATURE
DATE
SIGNATURE
CUSTOMER
ORDER-NO.
ITEM
CP-NO.