

# Overview of Centrifugal Pumps for Difficult Applications

## Boosting your Processes with Swiss Quality

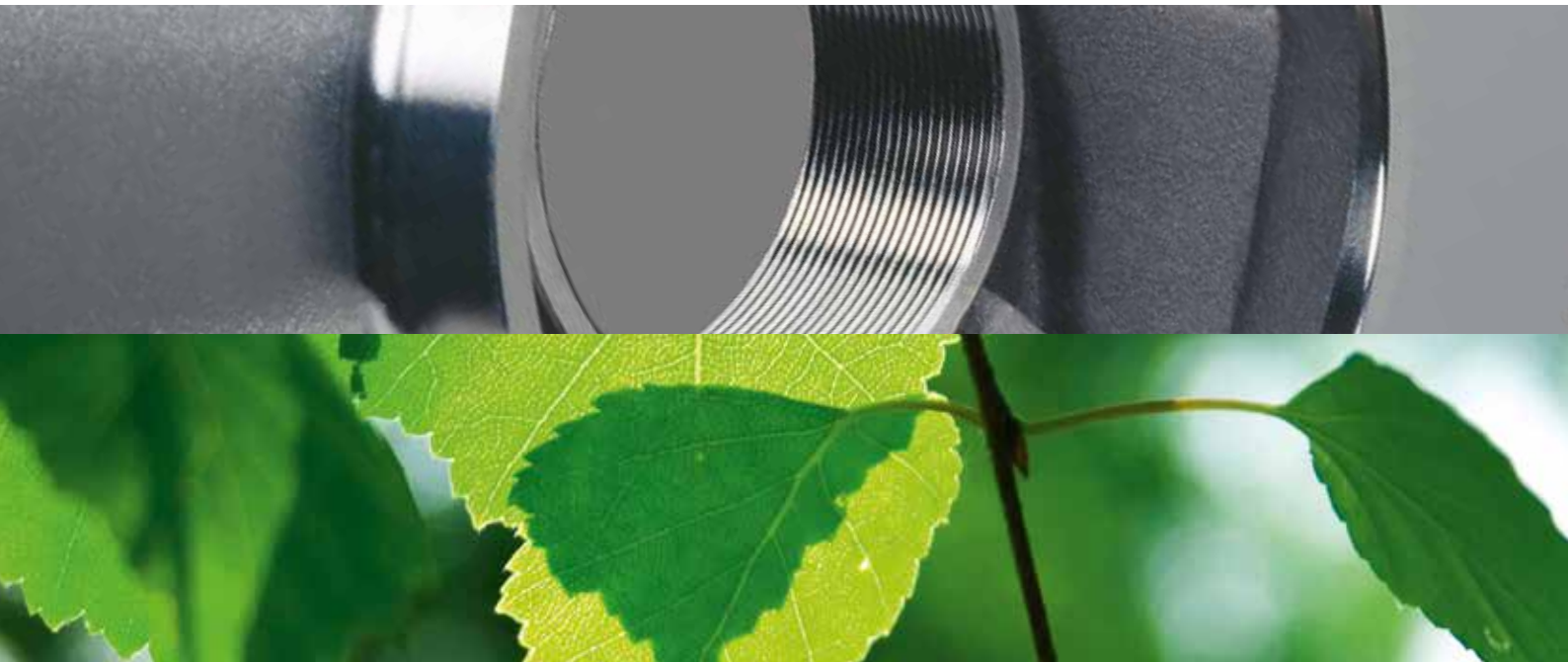

High-safety, hermetically sealed and efficient centrifugal pumps, produced and manufactured in Switzerland since 1948.

**Mastering challenges for your industry:**

- Chemical
- Petrochemical
- Pharmaceutical
- Biotechnology
- Food and beverages

# Magnetic Metallic Driven Pumps MKP

## Unique Drive Principle by CP

Up to 30% solids and 1 mm particle size can be pumped – depending on the nature of the particles.\*



MKP technical data

### MKP without heating chamber

The MKP's design offers key advantages over conventional pump designs:

- 1 The centrally located bearing assembly, minimal bearing loads and absence of a plain bearing carrier ensure highly reliable operation and allow superior handling of solids-laden fluids.
- 2 A large flush line branching off from the casing provides excellent lubrication and cooling of the bearing assembly with the pumped fluid.
- 3 The compact design with virtually no dead areas means that suspended solids can also be pumped.
- 4 Simple construction and few components make the pump very easy to assemble.

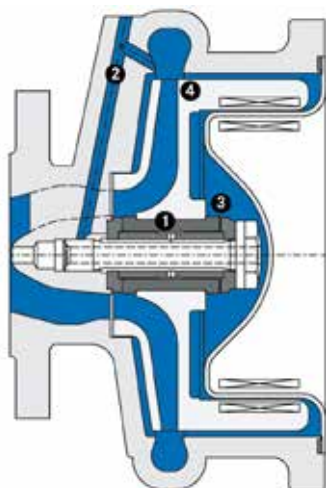

### MKP with heating chamber

The MKP's design offers key advantages over conventional pump designs:

- 5 Heating the entire pump with a single heating chamber cuts installation costs.
- 6 Excellent heat distribution in the interior of the pump reduces temperature differences and prevents cold zones.
- 7 High heat transfer efficiency, with the heating energy delivered directly into the fluid chamber, shortens heat-up times.

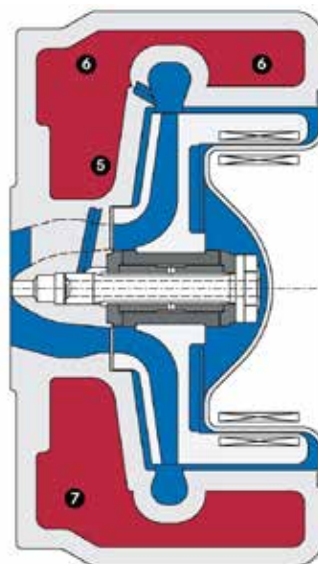

### MKP 300-250-315: The big one. Stainless steel magnetic drive chemical process pump for up to 1300 m<sup>3</sup>/h

The Sealless Magnetic Drive Pump MKP 300-250-315 is particularly well suited to the high demands in the chemical industry and many other industrial sectors. Thanks to its size and its performance, it is able to pump flow rates of up to 1300 m<sup>3</sup>/h with a head up to 55 m. Do you need to solve particularly challenging pumping tasks? That suits, because CP Pump Systems has centrifugal pumps with particularly good properties. As a Swiss pump manufacturer, CP Pump Systems develop and produce them especially for pumping difficult liquids.

\*Fluids with solids content can be pumped, depending on application and subject to prior technical evaluation.



# PFA-Lined Magnetic Driven Chemical Process Pump MKPL

## Extra Robust & High Temperature Resistant

Metal reinforcement with thick, corrosion- and diffusion-resistant PFA lining.



MKPL technical data

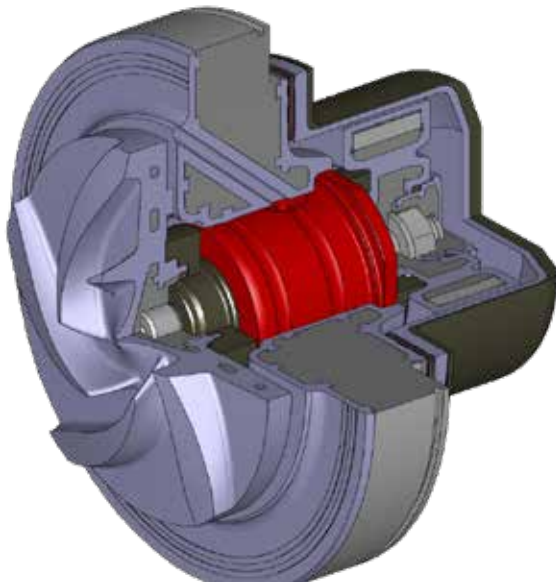

### MKPL – The corrosion and diffusion resistant centrifugal pump – even at high temperatures.

#### Special features

- Fluid temperature up to 200°C
- 100% vacuum-tight
- PFA-lined plain bearing carrier

#### Construction

- Compact and virtually free of dead space
- No shaft feedthrough and leak-free
- Single-part and central bearing
- Bearing made of pure SSiC (=highest operating safety)
- Plain bearings secured with polygonal form-fit, self-centring anti-rotation devices

#### Assembly and repair

- Bearing frame and motor can be dismantled (pump remains in the facility and is sealed to the outside)
- Modular system made up of few individual parts
- Assembly friendly

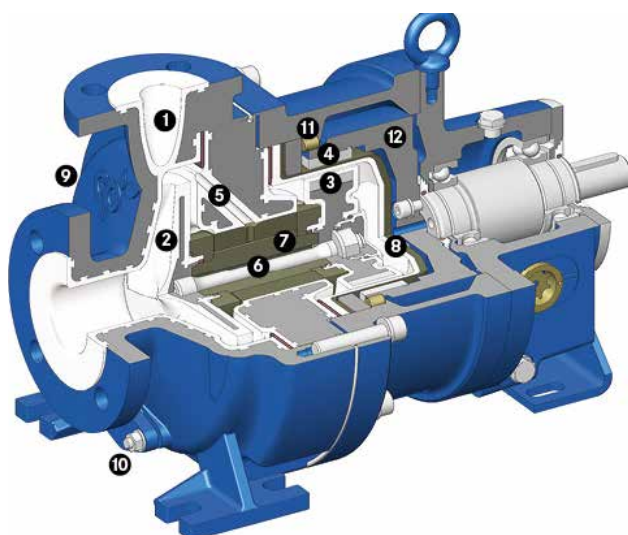

### MKPL – Bearing frame\* (-20°C to +200°C), horizontal

- 1 Pump casing with PFA lining
- 2 Impeller
- 3 Inner magnet assembly (on product side)
- 4 Outer magnet assembly (on atmospheric side)
- 5 Internal bearing lubrication
- 6 Single bolt with locking sleeve for the rotating unit
- 7 Plain bearing assembly
- 8 One-piece, vacuum-resistant, non-metallic containment shell
- 9 Pt100 temperature probe on casing
- 10 Casing drain
- 11 Bump pin
- 12 Flywheel

\*Also available in close coupled execution.

# Metallic Magnetic Driven Pumps for Chemicals, Solvents, Molten Products

## MKP - Stainless Steel Magnetic Drive Chemical Process Pump



Capacities	0.25 to 1300 m <sup>3</sup> /h
Heads	3 to 230 m
Temperatures	-100 to +350 °C
316, 304, Uranus® B6, Hastelloy®, Duplex, Titanium, Nickel	
MKP ANSI standard available for specific sizes.	



Not afraid  
of solids!



## MKP - Stainless Steel Magnetic Drive Chemical Process Pump With Heating Chamber



Capacities	0.25 to 1300 m <sup>3</sup> /h
Heads	3 to 230 m
Temperatures	-100 to +350 °C
316, 304, Uranus® B6, Hastelloy®, Duplex, Titanium, Nickel	



For quick  
heating up,  
no cold spots.



## MKP-Vertical - Stainless Steel Magnetic Drive Chemical Process Pump



Capacities	0.25 to 220 m <sup>3</sup> /h
Heads	0 - 72 m
Temperatures	-100 to +250 °C
316, 304, Uranus® B6, Hastelloy®, Duplex, Titanium, Nickel	



Compact

## MKPP - Stainless Steel Magnetic Drive In-Line Chemical Process Peripheral Pump



Capacities	0.25 to 4 m <sup>3</sup> /h
Heads	1 to 40 m
Temperatures	-100 to +200 °C
316, Uranus® B6, Hastelloy®	



Low flow



## MKP Bio - Stainless Steel Magnetic Drive Biotech Process Pump



Capacities	0.5 to 60 m <sup>3</sup> /h
Heads	5 to 80 m
Temperatures	-20 to +150 °C
316, Uranus® B6, Hastelloy®	
- 100% Clean-In-Place (CIP) and Sterilization-In-Place (SIP)	
- parts in contact with medium: Surface quality Ra ≤ 0.8, inside edges R3, surfaces inclined > 3°, 3A Sanitary Standard	
Possible certificates FDA, USP Class VI	



100% sanitary design,  
CIP, SIP



## SZMK - Stainless Steel Magnetic Drive In-Line Chemical Process Pump



Capacities	0.5 to 40 m <sup>3</sup> /h
Heads	1.4 to 22 m
Temperatures	-100 to +200 °C
316	



In-line





# Magnetic Driven Pumps PFA-Lined and Full PTFE for Corrosive Fluids

## MKPL – PFA-Lined Magnetic Drive Chemical Process Pump

Capacities	0.5 to 350 m <sup>3</sup> /h
Heads	3 to 80 m
Temperatures	-20 to +200 °C
Cast iron (GGG 40.3)/vacuum-tight PFA lining	



**200 °C,  
5 mm lining, permeation- and  
vacuum-resistant**

## MSKP – Solid PTFE Magnetic Drive Chemical Process Pump

Capacities	0.25 to 70m <sup>3</sup> /h
Heads	2 to 90 m
Temperatures	-20 to +100 °C
Carbon-filled PTFE, virgin PTFE, PVDF, shaft PFA-lined	



**Solid PTFE casing,  
non-ceramic shaft**

## MSKPP – Solid PTFE Magnetic Drive Chemical Process Peripheral Pump

Capacities	0.25 to 7 m <sup>3</sup> /h
Heads	3 to 130 m
Temperatures	-20 to +100 °C
Carbon-filled PTFE, virgin PTFE, PVDF, shaft PFA-lined	



**Low flow,  
heads to 130 m,  
solid PTFE casing**

## MSKS – Solid PTFE Self-Priming Magnetic Drive Chemical Process Side Channel Pump

Capacities	0.2 to 2.5 m <sup>3</sup> /h
Heads	1 to 34 m
Temperatures	-20 to +80 °C
Carbon-filled PTFE, virgin PTFE, PVDF, shaft PFA-lined	



**Self-priming,  
side channel PTFE mag-drive**

# Centrifugal Pumps with Mechanical Seals for Corrosive, Abrasive and Liquids with Particles

## EB – PFA-Lined Double Mechanical Seal Chemical Process Pump



Capacities	0.5 to 400 m <sup>3</sup> /h
Heads	5 to 100 m
Temperatures	-20 to +150 °C

Cast iron, vacuum-tight PFA lining, seal CP Futuratef®



**Corrosion-resistant**

## ET – Ceramic-Lined Double Mechanical Seal Chemical Process Pump



Capacities	0.5 to 300 m <sup>3</sup> /h
Heads	3 to 70 m
Temperatures	-20 to +150 °C

Cast iron, ceramic lining, seal CP Futuramik®



**Abrasion-, corrosion- and  
diffusion-resistant**

## ZMP – Stainless Steel Mechanical Seal Chemical Process Grinder Pump



Capacities	0.5 to 200 m <sup>3</sup> /h
Heads	2 to 10 m
Temperatures	-20 to +180 °C

316, 304, Uranus® B6, Hastelloy®, Titanium

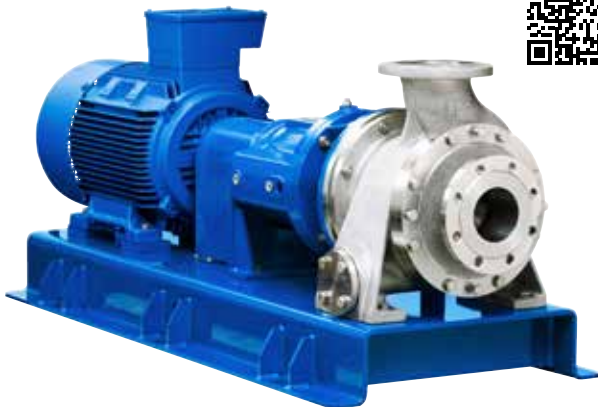

**3-In-One crushing pump:  
crushing + mixing + pumping  
for granulates**



# Magnetic Driven Pumps for Challenging Applications

## Self-priming, Submersible

### MKP-S - Stainless Steel Self-Priming Magnetic Drive Chemical Process Pump



Capacities	1 to 80 m <sup>3</sup> /h
Heads	5 to 60 m
Temperatures	-100 to +250 °C
316, 304, Uranus® B6, Hastelloy®, Titanium	

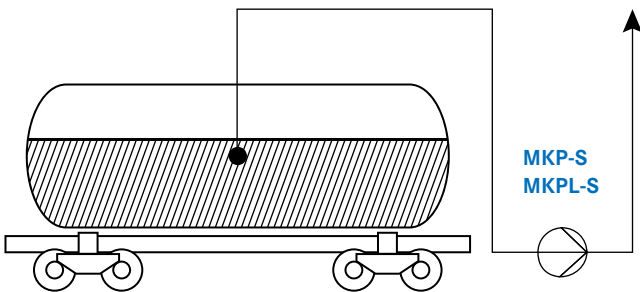

### MKPL-S - PFA-Lined Self-Priming Magnetic Drive Chemical Process Pump



Capacities	0.5 to 35 m <sup>3</sup> /h
Heads	3 to 40 m
Temperatures	-20 to +150 °C
Cast iron (GGG 40.3)/vacuum-tight PFA lining	



### MKTP - Stainless Steel Magnetic Drive Chemical Process Sump Pump



Capacities	0.25 to 250 m <sup>3</sup> /h
Heads	3 to 100 m
Temperatures	-20 to +175 °C
316, 304	

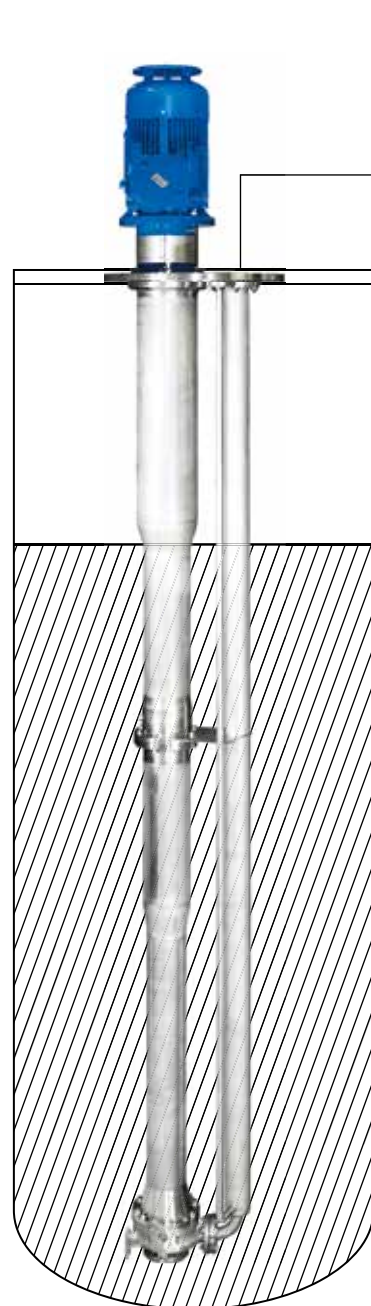



# CP Pumpen Services For the Heart of Your Plant

## Without them, Definitely Nothing Works

Pump repairs or maintenance work sometimes arise even with the best pump. In the event of damage, above all the response must be fast!

As a customer of CP Pumpen you benefit from our competence and expertise as the original manufacturer. In case of repairs we use original spare parts. We thereby always ensure maximum, good as new quality. The value of the CP pumps is retained and the investment pays off.



To your Service Support

## Your Advantages

All customers can access our factory repair service in Zofingen. We can also carry out comprehensive repairs at short notice in our in-house workshop.

Our committed pump experts and well-equipped, modern machinery guarantee that your centrifugal pumps will be improved or repaired flexibly and efficiently.

- Short reaction times and fast solutions
- Service and repairs in familiar CP quality
- Choice between local Service Partner or CP workshop
- Long-term value retention of the pump
- Lower life cycle costs thanks to regular service

# CP Pumpen Spare Parts & Repairs Original – Fast – Reliable



## Headquarters

**CP Pumpen AG**  
Switzerland, Zofingen



**SWISS  
MADE**

## Distribution companies

**CP Pumpen GmbH**  
Germany, Mannheim

**CP Pompes SAS**  
France, Strasbourg

**CP Pumps Inc.**  
USA, Birmingham (AL)

**CP Pumps Thailand**  
Thailand, Bangkok

**CP Pump Limited 씨피 펌프 유한회사**  
Republic of Korea, Seoul

Find your local CP distributor  
on [www.cp-pumps.com](http://www.cp-pumps.com)  
or contact CP directly: +41 62 746 85 85  
[info@cp-pumps.com](mailto:info@cp-pumps.com)

