

# PFA Lined Magnetic Drive Centrifugal Pumps

## Efficient – Non-Corroding – Vacuum-Resistant

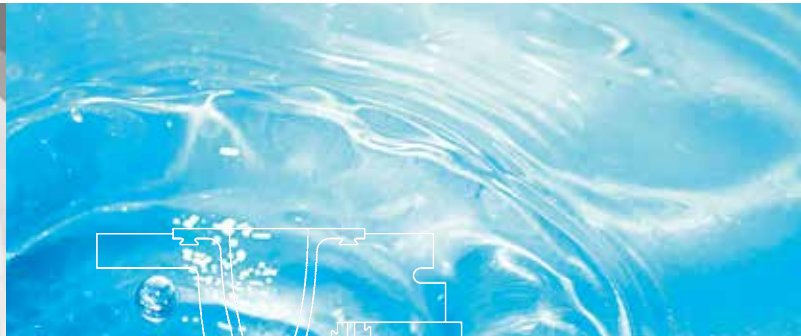

### **MKPL**

Magnetic drive chemical process pump

### **MKPL-S**

Self-priming magnetic drive chemical process pump

Designed to:

DIN EN ISO 2858, 5199 and 15783

Compliant with:

EC Machinery Directive

EC ATEX Directive

FDA 21 CFR §177

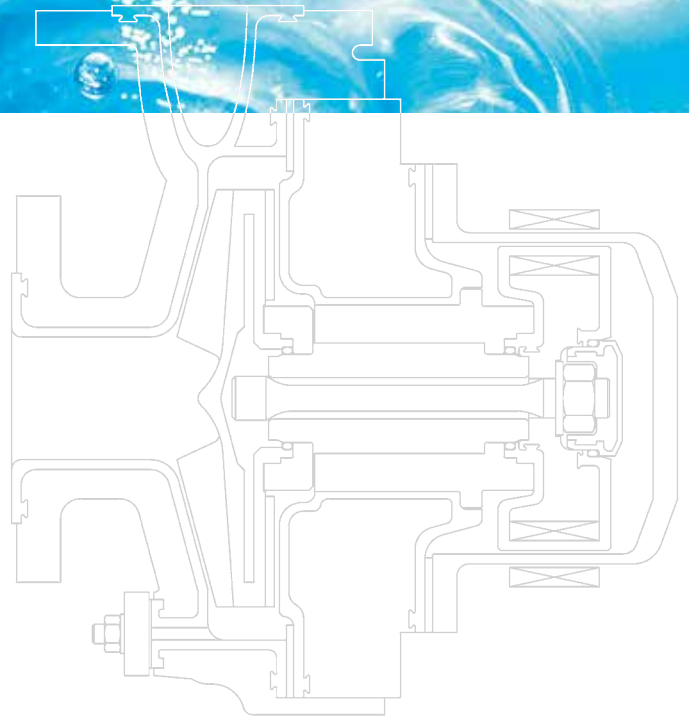



Open impeller of PFA lined magnetic drive pumps



# CP Pump Systems

## PFA Lined Magnetic Drive Centrifugal Pumps

### Our company

CP is a highly innovative Swiss company with a rich tradition. Since 1948 we have specialised in developing and manufacturing premium quality high-tech products and providing services for international customers with the most rigorous requirements.

We produce reliable and innovative centrifugal pumps for the chemical, pharmaceutical, petrochemical, biotechnology, food and beverage industries. CP is represented in over 70 countries through its network and offers first-class customer services. This proximity guarantees customers worldwide an efficient local service.

Reflecting our deep commitment to energy efficient products and services, we deliver environmentally friendly solutions that always go hand in hand with maximum safety and economy. As a pioneer in this area, we advise and assist customers with a wide range of needs – throughout the value chain.

CP operates a quality management system certified to ISO 9001:2015.

### PFA lined magnetic drive centrifugal pumps

With their sealless design, the MKPL and MKPL-S magnetic drive pumps are ideal to meet the stringent requirements of chemical processing and a multitude of other industries. These highly advanced and extremely energy efficient pumps are built to handle a huge variety of corrosive fluids reliably and absolutely safely, especially even in high temperature applications.

The pump casing has a thick, heavy-duty, corrosion- and permeation-resistant PFA lining, mechanically locked into the metal armour, ensuring vacuum resistance. This armour absorbs mechanical stresses that can result from system pressure or piping nozzle loads.

Made of pure SSiC (sintered silicon carbide) in a robust design engineered for ceramics, the bearing assembly provides maximum reliability of pump operation. Plain and thrust bearings are secured with polygonal form-fit, self-centring anti-rotation devices.

The MKPL and MKPL-S pumps come with either an open impeller or a closed impeller. The impellers consist of a metallic core for mechanical strength and a thick PFA lining which is firmly connected with the core.

Both pumps are constructed with just a few, robust components using an intelligent modular system that facilitates assembly and minimises the costs of spare parts, maintenance and servicing.

# MKPL

## PFA Lined Magnetic Drive Chemical Process Pump

Designed for operating at up to +200°C, the MKPL pump is built for safety in handling corrosive fluids in high temperature applications. Its connection dimensions and performance data conform to DIN EN ISO 2858, making the MKPL easy to retrofit into any installation to replace old pumps.

Technical data	
Capacities (min./max.)	0.5 to 350 m <sup>3</sup> /h
Heads (min./max.)	3 to 80 m
Temperatures (min./max.)	-20 to +200°C
Kinematic viscosities	0.5 to 350 mm <sup>2</sup> /s
Solids handling	up to 10% solids concentration, depending on the pumped fluid*

Directives	
EC Machinery Directive	
EC ATEX Directive	
FDA 21 CFR §177	
Standards	
DIN EN ISO 2858	
DIN EN ISO 5199	
DIN EN ISO 15783	

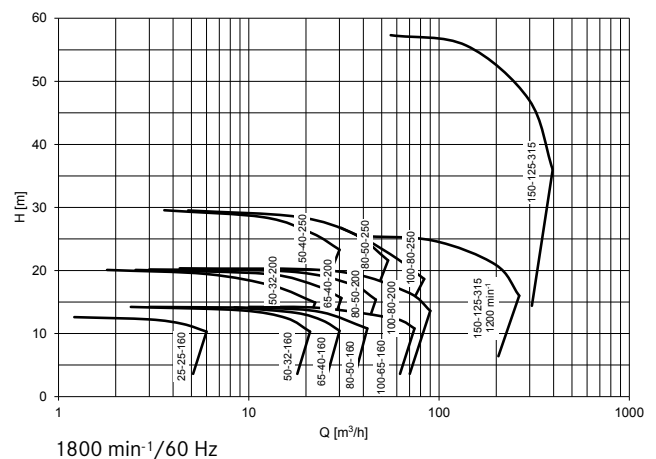
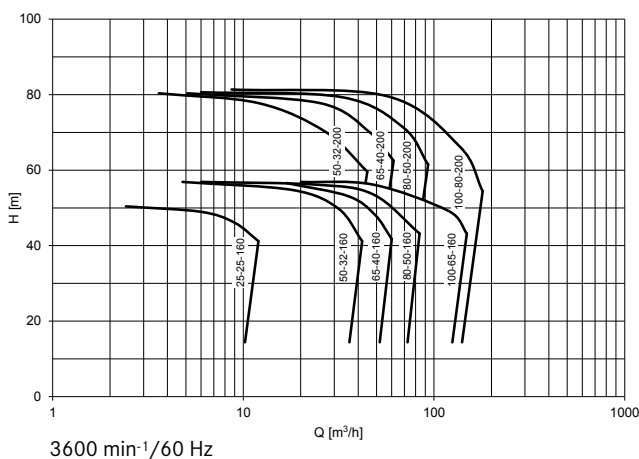
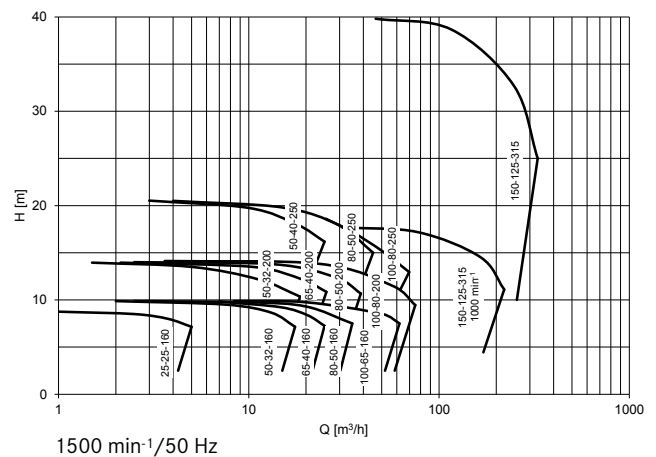
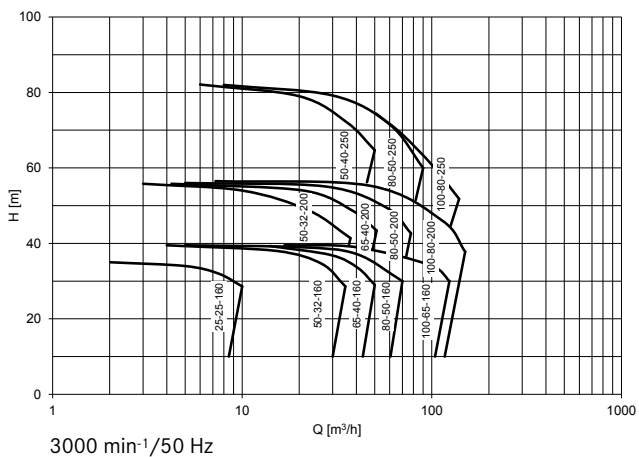

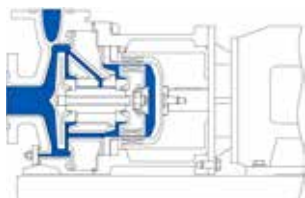

**Close-coupled MKPL**  
with baseplate  
-20 to +200°C

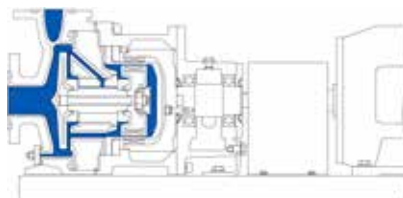

**Bearing frame-mounted MKPL**  
with baseplate  
-20 to +200°C



**MKPL with baseplate and motor**  
horizontal close-coupled (-20 to +200°C)

# MKPL-S

## PFA Lined Self-Priming Magnetic Drive Chemical Process Pump

The MKPL-S features an integral priming chamber in the casing. A separate priming tank is not necessary because the pump evacuates the suction line itself by creating a vacuum. The MKPL-S can even readily pump entrained air in the suction line while running, thus increasing reliability of operation. This pump achieves suction lifts up to 8 m.

### Technical data

Capacities (min./max.)	0.5 to 35 m <sup>3</sup> /h
Heads (min./max.)	3 to 55 m
Temperatures (min./max.)	-20 to +150°C
Kinematic viscosities	0.5 to 350 mm <sup>2</sup> /s
Solids handling	up to 10% solids concentration, depending on the pumped fluid*

### Directives

EC Machinery Directive  
EC ATEX Directive

### Standards

DIN EN ISO 5199  
DIN EN ISO 15783

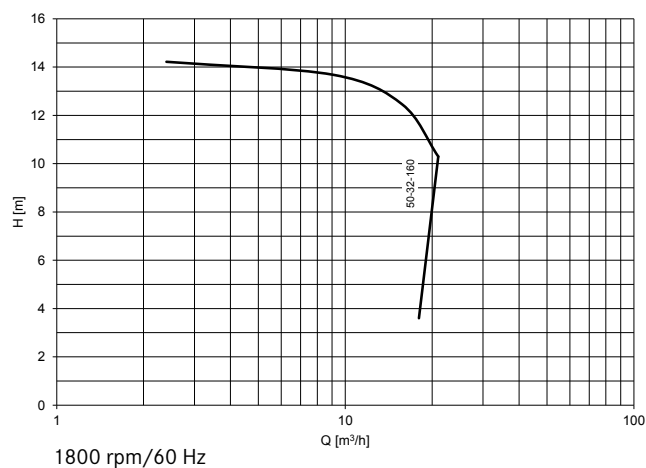
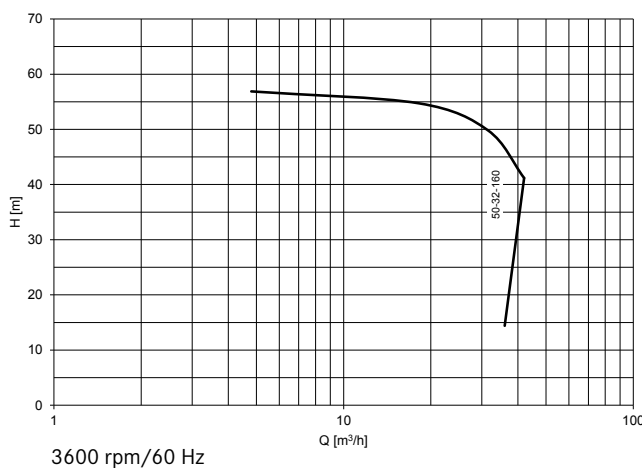
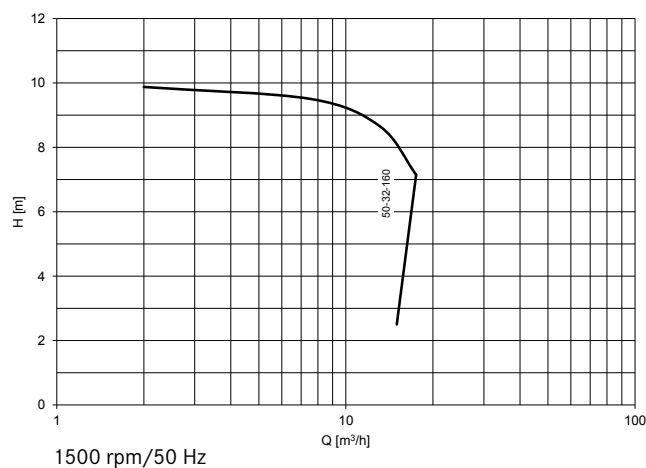
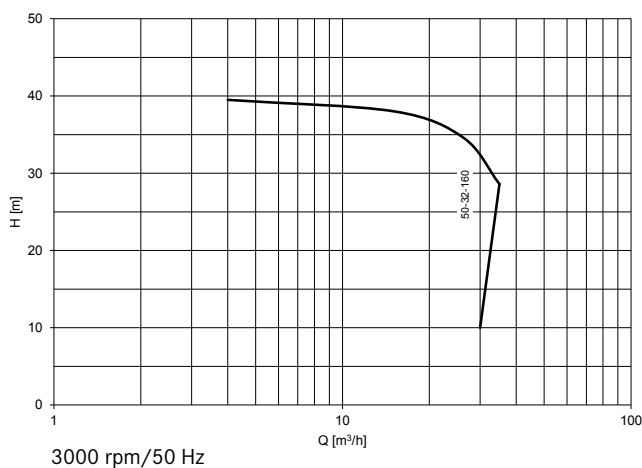

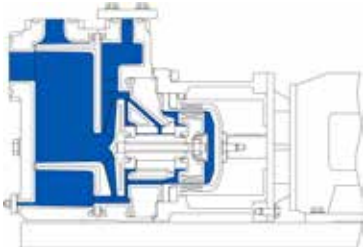

**Close-coupled MKPL-S**  
with baseplate  
-20 to +150°C

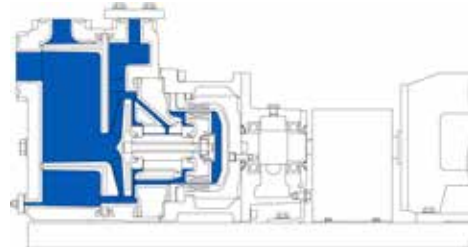

**Bearing frame mounted MKPL-S**  
with baseplate  
-20 to +150°C



**MKPL-S with baseplate and motor**  
horizontal close-coupled (-20 to +150°C)



PFA lined bearing carrier



# Applications

## Versatile – Complex – Special

CP's PFA lined magnetic drive pumps are engineered to meet the most stringent quality standards and ensure reliability and utmost safety in production operations. Suitable for many different fluids in a variety of industries and processes, they are capable of handling low, medium and high flow volumes. PFA lined magnetic drive pumps from CP offer tremendous advantages, especially in pumping sensitive or hazardous substances.

---

### Industries

---

- Chemical processing: basic and fine chemicals (agrochemicals, speciality chemicals)
- Pharmaceuticals
- Biotechnology processing

---

### Processes

---

CP's PFA lined magnetic drive pumps are designed for a wide range of processes, including:

- Chlor-alkali electrolysis
- Sulphuric acid recycling
- Tank unloading

---

### Fluids

---

CP's PFA lined magnetic drive pumps can handle hot and/or highly concentrated acids, alkalis (bases), solvents and diffusing fluids.

For example:

- Bromine
- Chlorine
- Nitric acid
- Phosgene
- Potassium hydroxide solution
- Sodium hydroxide solution
- Sulphuric acid

Our sales staff will be glad to give you personalised advice tailored to your specific needs, industry, processes and fluids.



# Options

## Comprehensive – Individual – Combinable

---

### Casing

---

#### Materials

- Cast iron (GGG 40.3)/vacuum-tight PFA lining

#### Pressure rating

- PN 16

#### Connection flanges

- To EN 1092-2
- Drilled to ANSI/ASME B16.5

#### Additional connections

- Casing drain (with or without flange)
- External flush connection for bearing lubrication and/or flushing and cooling the magnet assembly (for type MKPL)
- Lantern monitoring connection

#### Gasket materials

- PTFE
- PTFE/graphite

#### O-ring materials

- FEP/FKM
- Kalrez®/FFKM



---

### Bearing assembly

---

#### Materials

- SSiC (sintered silicon carbide)
- SSiC with diamond-like coating (ADLC)
- SSiC with FuturaSafe® (chemical vapour deposition diamond coating)



---

### Containment shell

---

#### With containment shell monitoring

#### Materials

- Heat-resistant carbon fibre reinforced PTFE
- Carbon fibre reinforced PVDF
- Alloy 600





---

### Pump protection

---

**Containment shell leakage monitoring**

**Pt100 temperature probe**

**Motor load sensor**



---

### Mounts

---

**Type**

- Baseplate
- Horizontal

**Materials**

- Steel
- Stainless steel

**Stilts**

**Drip pan**

**Grounding lugs**



---

### Bearing frame

---

**Lubrication**

- Oil lubrication
- Grease lubrication

**Oil lubrication options**

- Hermetic seal (MagTecta OM™)
- Constant level oiler

**Coupling**

**Coupling guard**

- Steel
- Brass



The options vary depending on the pump model. Our sales staff will be glad to advise you in detail.

## Sectional View

### MKPL

Bearing frame (-20 to +200°C), horizontal

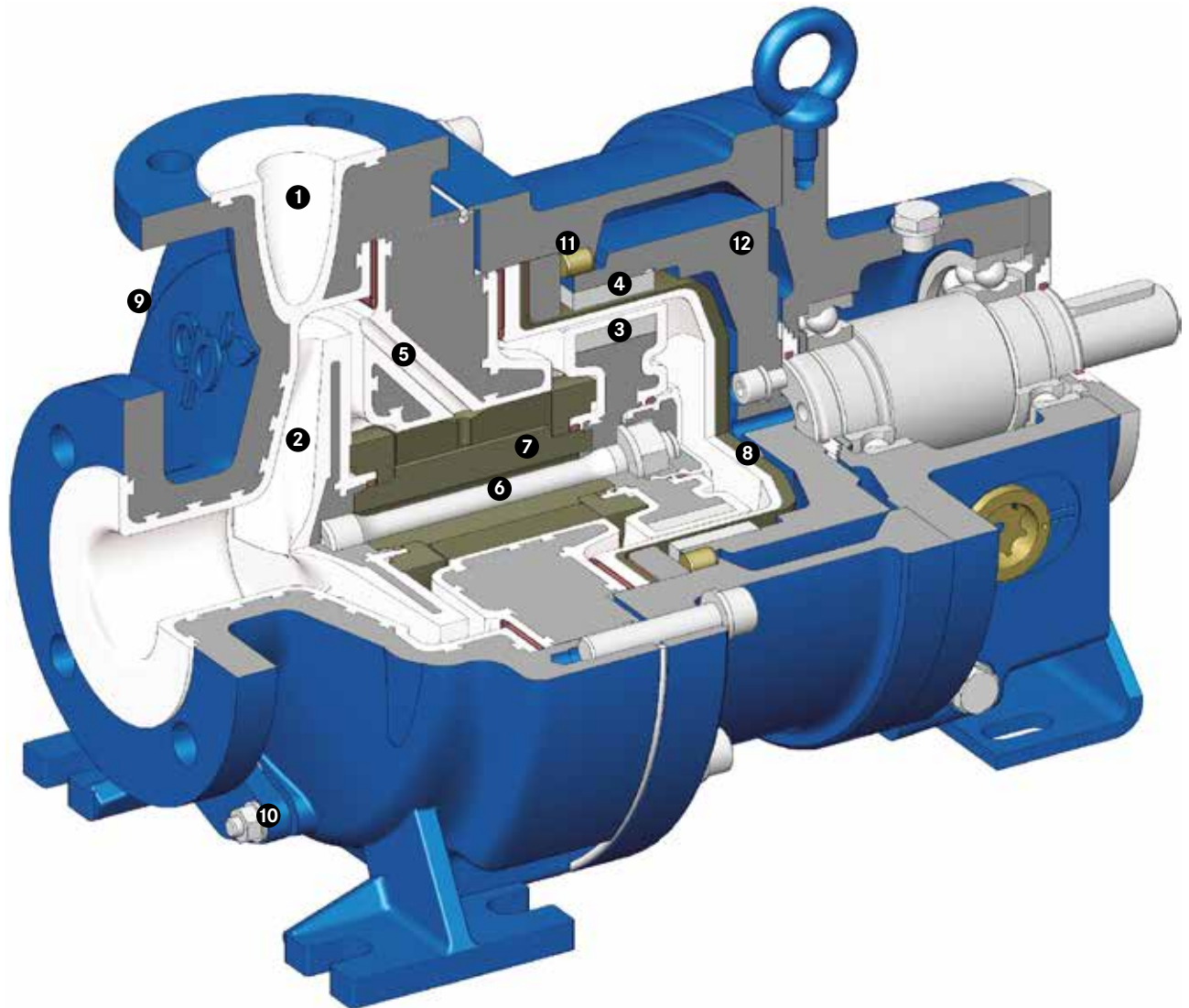

- |  |   |
|--|---|
| 1 Pump casing with PFA lining                                      | 8 One-piece, vacuum-resistant, non-metallic containment shell |
| 2 Impeller   | 9 Pt100 temperature probe on casing                           |
| 3 Inner magnet assembly (on product side)                          | 10 Casing drain   |
| 4 Outer magnet assembly (on atmospheric side)                      | 11 Bump pin   |
| 5 Internal bearing lubrication                                     | 12 Flywheel   |
| 6 Single locking sleeve for rotating unit fasten the rotating unit |   |
| 7 Plain bearing assembly   |   |



# CP Pump Systems

## Our Product Portfolio

### Customer service

We offer the highest quality, many years of experience and first-class advice from a single source. Our bespoke pump systems meet a wide range of different requirements.

CP's customers benefit from a full service offering: the fastest availability of genuine spare parts, a complete set of technical documentation, competent and efficient customer support, and a dynamic and flexible repair service. All these services ensure that your pumps will operate faultlessly. Thanks to a network in over 70 countries, we advise and serve our customers directly on site.

### Energy efficiency consulting

As a trend scout specialised in energy efficiency, CP can deliver a wide spectrum of services relating to pumps and motors: comprehensive advice, in-depth system analysis, meticulous planning and design. Our goal is to actively help our customers optimise the energy consumption of their pumping systems and thereby cut costs over the long term.

Backed by our many years of broad experience, we today advise and assist customers in both the private and public sectors. These include owners and operators of fluid processing plants in the chemical, pharmaceutical and diverse other industries.

Are you interested? Do you have any questions? We would be happy to discuss all the different options with you personally.

---

### Stainless steel magnetic drive centrifugal pumps

---

#### MKP

Magnetic drive chemical process pump

---

#### MKP-S

Self-priming magnetic drive chemical process pump

---

#### MKTP

Magnetic drive chemical process sump pump

---

#### MKP-ANSI

Magnetic drive chemical process pump

---

#### MKPP

Magnetic drive in-line chemical process peripheral pump

---

#### SZMK

Magnetic drive in-line chemical process pump

---

#### Mobile centrifugal pump

Mobile magnetic drive chemical process pump

---



---

### Stainless steel magnetic drive biotech process pump

---

#### MKP-Bio

Magnetic drive centrifugal pump for sterile processes

---



---

### PFA lined magnetic drive centrifugal pumps

---

#### MKPL

Magnetic drive chemical process pump

---

#### MKPL-S

Self-priming magnetic drive chemical process pump

---



---

### Solid PTFE magnetic drive centrifugal pumps

---

#### MSKP

Magnetic drive chemical process pump

---

#### MSKPP

Magnetic drive chemical process peripheral pump

---

#### MSKS

Self-priming magnetic drive chemical process side channel pump

---



---

### Stainless steel mechanical seal centrifugal pumps

---

#### ZMP

The 3-In-One mechanical seal chemical process pump: crushing, mixing and pumping

---



---

### PFA lined double mechanical seal centrifugal pump

---

#### EB

Double mechanical seal chemical process pump

---



---

### Ceramic lined double mechanical seal centrifugal pump

---

#### ET

Double mechanical seal chemical process pump

---

Yale



cp pump



## Energy efficiency in industry sustainable – responsible – ecological

Nowadays, industry is facing increasing demands to improve sustainability and energy efficiency. Pumps are considered to play a key role because they offer vast potential to save energy and costs. Already recognising this back in 1999, CP took action and has become a pioneer in energy-saving pumping systems.

In recent years, we have continuously enhanced the hydraulic performance of numerous pump systems, increasing their efficiency by up to 30 per cent. At the same time, we have steadily improved pump safety, a mission we have vigorously pursued ever since our company was established in 1948.

We are wholeheartedly committed to promoting sustainable manufacturing in industry around the world. Our customers benefit from a comprehensive range of solutions that reduce costs and CO<sub>2</sub> emissions over the long term. Cleaner pumps, cleaner planet: we firmly believe that sustainable research, thinking and action always pay off for everyone.





## Improving Energy Efficiency in Pumping Systems Helps to Create a Cleaner Planet.

### Headquarters

**CP Pumpen AG**  
Switzerland, Zofingen



**SWISS  
MADE**

### Distribution companies

**CP Pumpen GmbH**  
Germany, Mannheim

**CP Pompes SAS**  
France, Strasbourg

**CP Pumps Inc.**  
USA, Birmingham (AL)

**Representative Office of CP Pumpen AG**  
Thailand, Bangkok

**CP Pump Limited 씨피 펌프 유한회사**  
Republic of Korea, Seoul

Please find your local CP distributor on  
[www.cp-pumps.com](http://www.cp-pumps.com).  
or contact CP directly:  
[+41 62 746 85 85 /info@cp-pumps.com](mailto:info@cp-pumps.com).

