

MKP

Stainless Steel Magnetic Drive Chemical Process Pump

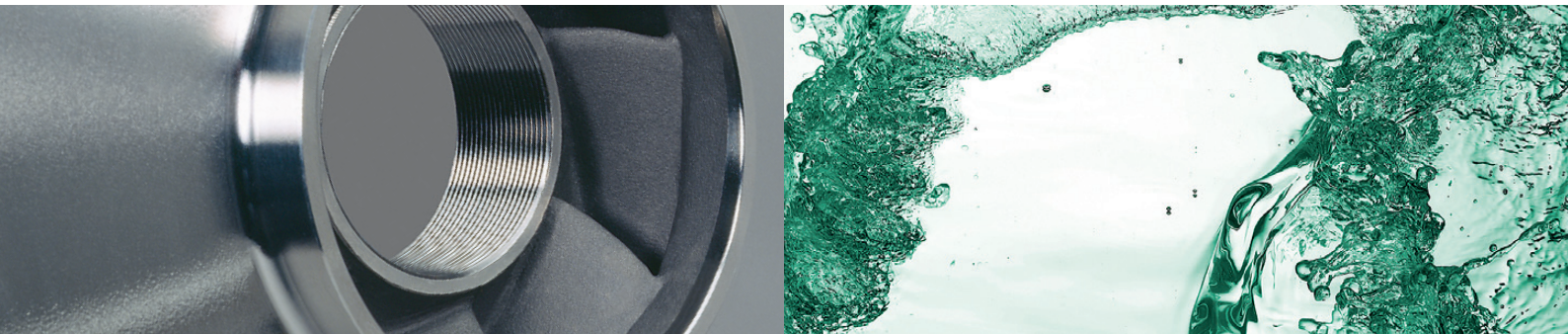

The sealless MKP magnetic drive pump is ideal to meet the stringent requirements of chemical processing and a multitude of other industries. This highly advanced and extremely energy efficient pump is built to handle a huge variety of fluids reliably and absolutely safely.

The MKP operates according to the unique CP drive principle with central bearing. With its special design, the pump requires no plain bearing carrier. The pumped fluid provides optimum lubrication and cooling of the single, centrally located impeller bearing assembly, also allowing solids-laden and low-boiling liquids to be pumped. Depending on the pumped medium, it can handle fluids containing solids in concentrations up to 30% with a particle size up to 1 mm.

The pump impeller rotates stably about a stationary axis on the gyroscopic principle, maintaining a perfect hydraulic balance. This minimises bearing loads, increasing the reliability of pump operation.

Added to its compact design with virtually no dead areas, the MKP is constructed with just a few, robust components. An intelligent modular system facilitates assembly and keeps the costs of spare parts, maintenance and servicing to a minimum.

The MKP is available in a variety of designs and configurations. In particular, a heat jacketed version allows molten sulphur to be pumped. Its connection dimensions and performance data conform to DIN EN ISO 2858, making the MKP easy to retrofit into any installation to replace old pumps.

Configurations

Close-coupled, bearing-frame

Mounts

- Baseplate
- Bracket
- Stand
- Angle stand
- Centreline support
- Stilt support plate
- Horizontal/vertical
- In-line

Casing materials

- Stainless steel 1.4581 (316Nb)*
- Stainless steel (e.g. 1.4306, Uranus® B6)*
- Duplex alloys (e.g. 1.4517)
- Nickel-base alloys (e.g. Hastelloy® C-4, C-22)*
- Nickel (e.g. 2.4170)
- Titanium alloys
- Ceramic coating (Al₂O₃)

*Also available for casing **with heating chamber**

Pump protection

- Containment shell temperature monitoring
- Pt100 temperature probe
- Engine load sensor
- Secondary Containment

Industries, processes and fluids

Learn more about typical applications:





Technical data

Capacities (min./max.)	0.25 to 1300 m ³ /h 1.1 to 5723.73 gpm
Heads (min./max.)	3 to 145 m 9.84 to 475.72 ft
Temperatures (min./max.)	-100 to +350°C -148 to 662°F
Kinematic viscosities	0.5 to 350 mm ² /s cSt
Solids handling	up to 30% solids concentration and 1 mm particle size, depending on the pumped fluid

Directives and standards

EC Machinery Directive

EC ATEX Directive

DIN EN ISO 2858

DIN EN ISO 5199

DIN EN ISO 15783

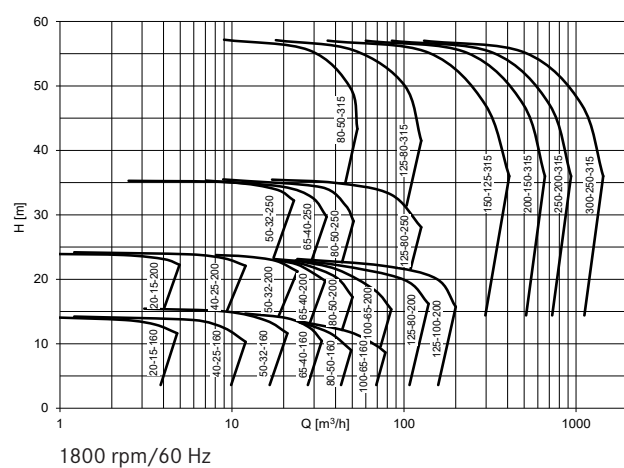
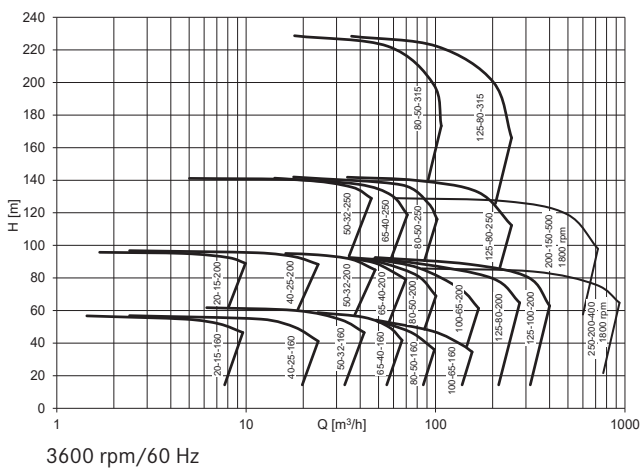
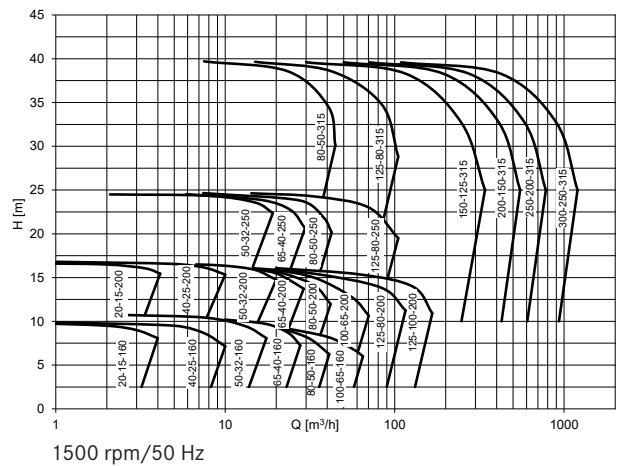
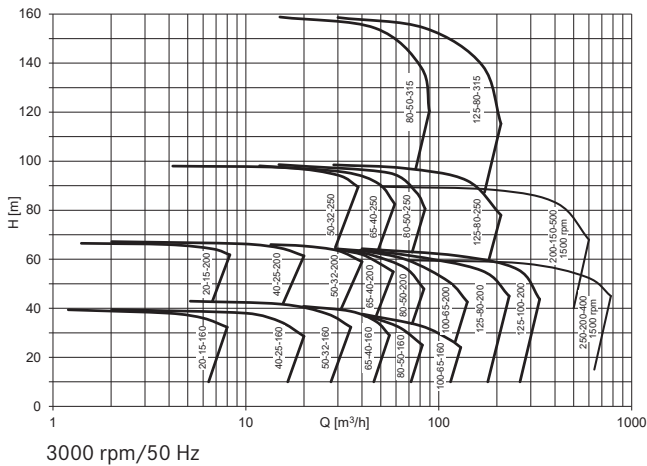

Find your local CP distributor on www.cp-pumps.com or contact CP directly:
+41 62 746 85 85/info@cp-pumps.com

